



Axiom Technologies LLC

255 Pennbright Dr. Suite 220
Houston, Texas 77090

Telephone: 281 931 0907

Fax: 281 231 6562

www.axiomsafety.com

MX16

USER'S MANUAL

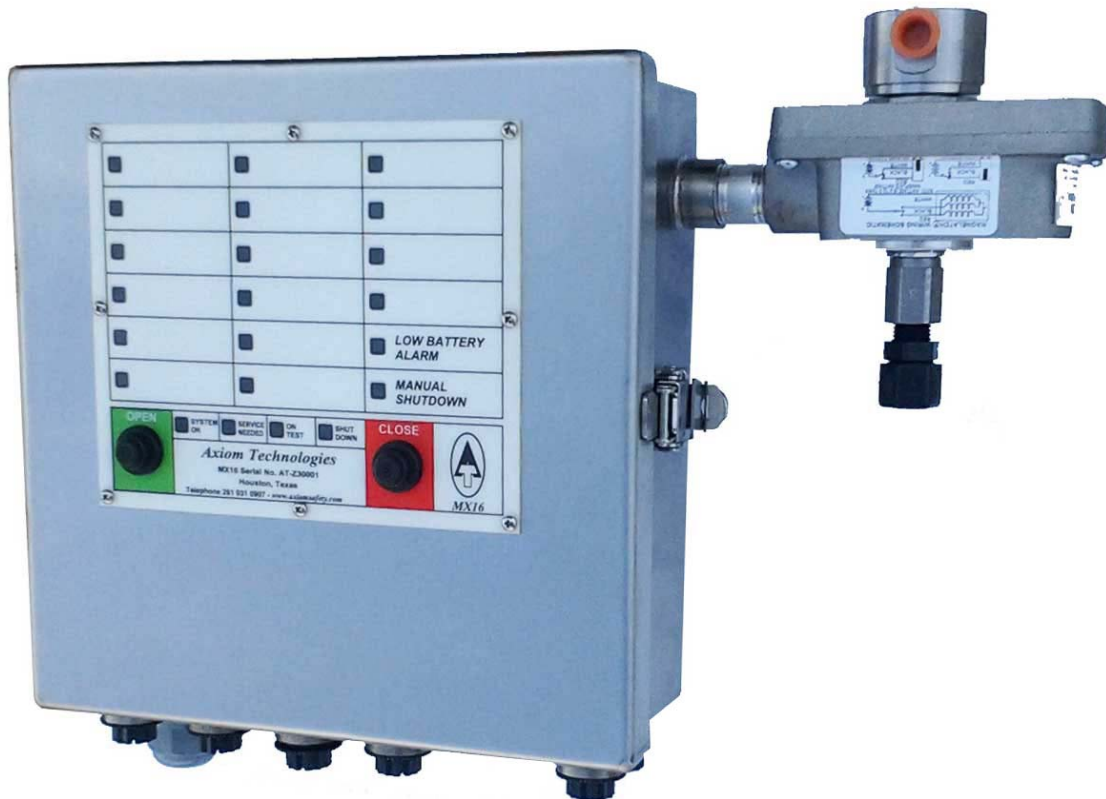

COMPACT MULTI-CHANNEL SHUTDOWN SYSTEM

GENERAL

The MX16 alarm and shutdown system is a self supported, compact shutdown device that has been designed to provide a safe and reliable means to react to abnormal production process conditions and initiate a shutdown if any of the connected devices show the operation is no longer within the pre-set safety margins.

The system has been built to withstand the adverse conditions of the oil-field environment and provide a straightforward interface with the operator. Abnormal conditions are indicated by indicator lamps (LEDs), each associated with a front panel label indicating the condition detected.

Powered by primary lithium batteries, the system is expected to operate for about three years before battery replacement. Little to no maintenance is needed besides recommended periodic function testing.

The MX16 can connect up to sixteen (16) loop monitored external alarm inputs and six (6) solid state outputs for indicating shutdown and service alerts respectively.

The alarm channels can be connected to any “dry contact” (or “open collector”) type of sensor such as pressure or level switches, manual ESD stations, and telemetry shutdown commands, etc. Each remote loop is monitored for wire integrity to insure that wiring faults are also detected.

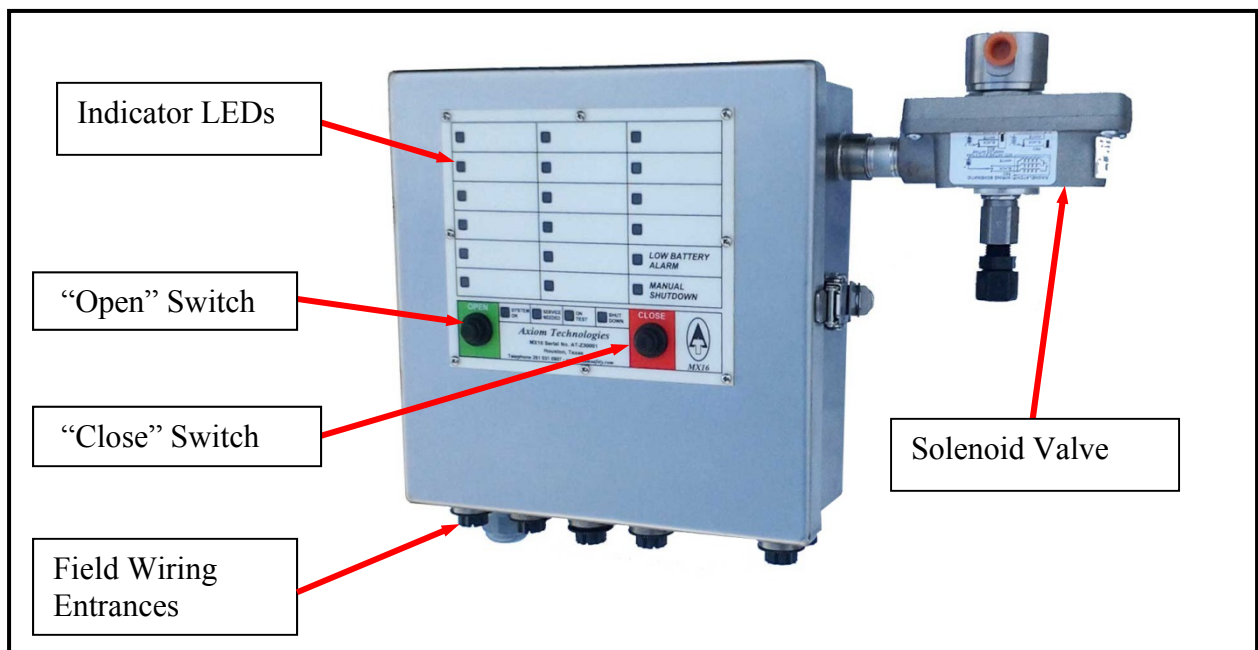

Fig. 1 MX16 General Layout

INSTALLATION

The enclosure of the MX16 is made of stainless steel and is provided with a pair of Strut Channels located on the back of the unit; it can be mounted on any vertical pole or pipe of up to 6” Outside Diameter.

THE MX16 ENCLOSURE IS TO BE MOUNTED UPRIGHT IN THE VERTICAL POSITION ONLY.

BATTERY PACK INSTALLATION AND ACTIVATION

Typically, the MX16 is shipped with the battery module installed in the “storage position”. To insure correct operation of the MX16 proceed as follows:

1. Remove the four nylon nuts holding the battery module, rotate the module 180° and carefully re-install as shown below (see Fig. 2).
2. Press and release the “RESET” switch located in the upper center of the main board. The MX16 responds by testing all the LEDs and then blinks the System OK green LED every second.

Confirm that the well is either locked open or manually closed to prevent unintended operation before proceeding with the next step.

3. Press “Open” on the left switch located on the front of the panel. The MX16 responds with a fast flashing of the “System OK” green LED followed by the normal flashing of once per second. Now the MX16 is ready to assume safety monitoring operation.

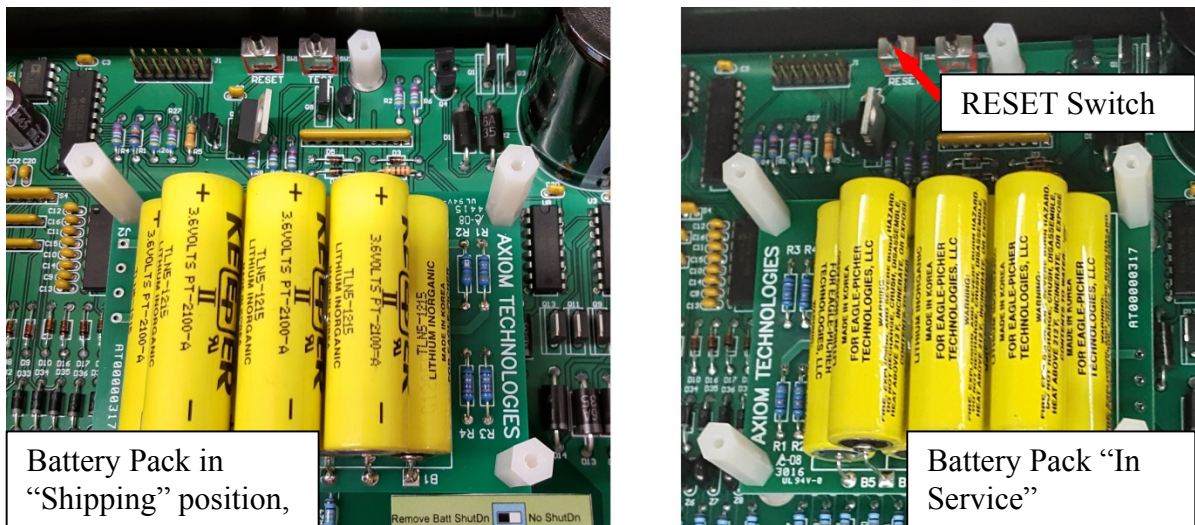

Fig. 2 Battery Pack installation

THE BATTERY PACK IS TO BE REPLACED ONLY WITH AXIOM BATTERY MODULE PART # AT0000001(Previously AT-LBP-36144)



ELECTRONIC SYSTEM

The electronic circuits, sixteen (16) alarm inputs and six (6) outputs, are shown in Appendix "A" – MX16 Installation Notes, Drawing No. AT-MX16-I.



WARNING – EXPLOSION HAZARD

- **DO NOT DISCONNECT EQUIPMENT OR REPLACE COMPONENTS UNLESS THE AREA IS KNOWN TO BE NON-HAZARDOUS**
- **PROTECTION MAY BE IMPAIRED IF THIS DEVICE IS USED IN AN APPLICATION OR MANNER NOT SPECIFIED IN THIS MANUAL**

The bottom of the enclosure has a total of ten (10) 1/2" NPT female fittings, where compatible cable glands or conduits may be connected for field wiring.

FIELD WIRING

***For proper grounding and safe operation, the terminals indicated in the photo below (J5 and J7) must only be supplied by a circuit with a suitable galvanic isolation barrier. In addition, all field devices connected to terminals J3 and J6 must withstand a dielectric strength test of 500Vrms between the intrinsically safe circuit and the frame of the device.**

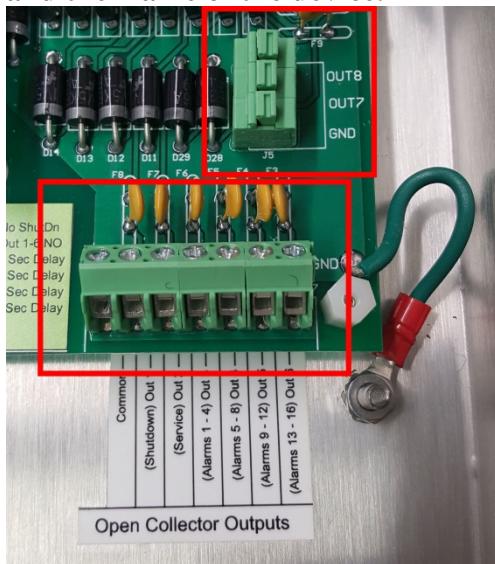

For reliable operation, the wire used for connecting to the alarm switches, must retain reasonably good insulation resistance values. Severe wiring decay can be avoided by selecting the proper type of cable. If the cable is to be buried, then selecting a cable that will maintain a reasonable level of insulation resistance is critical.

Given the low currents involved with the alarm signals, the wiring selected can be as thin as #30 AWG and still operate satisfactorily at distances of over 3,000 FT. One of the best choices for wiring field sensors is to use direct burial suitable cable.

If the wire is to be run in conduits, then it must be verified that the wire insulation will not decay when wet, as water tends to accumulate in conduits, especially if run underground. If the insulation resistance would severely decay and fall below 100 KOhm, then the system may be unable to recognize conditions of open circuits (wiring failure) in the loop.

If the wiring is to be spliced, then the splicing is to be made in a junction box above ground or the proper repair kit is to be used for insuring the insulation's integrity.

The MX16 operates with "Normally Open" circuits as normal condition. For monitoring wiring integrity, an "End Of line Zener" is connected in parallel with the corresponding normally open contact of the alarm switch. It is to be noted that the current for the inputs is well below incandive levels and the highest current any given input can produce is below 20 mA at a theoretical 16.8vdc.

The EOZs are shipped connected within the enclosure. When connecting an alarm to the MX16, the EOZ is to be moved from the box and connected in parallel with the alarm switch.

For example, if a "Water Tank High Level" alarm is to be connected to channel No. 1, then the end of line Zener at terminal TB1, position 1 (Labeled as 01) is to be connected to the pair of wires ("Signal" and "Common") running up to the tank. Then the EOZ is to be connected in parallel with the level switch at the water tank.

Assuming that a direct burial cable is being used, it may have a white wire as one conductor in each pair. It is common practice to parallel all white conductors in such a way that any white wire would provide the needed "common" point to the sensor being connected.

If junction boxes are used, the same practice of connecting all white wires together offers a great simplification, as it eliminates the need to carefully select the correct white wire for any given alarm switch.

By observing the alarm LEDs on the front panel of the MX16, the installer can determine if a given alarm sensor has been correctly connected. For example, if the wiring to the alarm switch connected to channel No. 3 has not been properly connected, then the LED

associated with channel No. 3 will remain double-blinking and the MX16 would not respond to the command for opening the SSV.

If there is a short circuit on the loop to channel No. 3 or the EOZ has been connected backwards, then Channel No. 3 will remain in alarm (single blinking). The opening of the SSV would be allowed but for only a limited amount of time, as the MX16 will shutdown if the existing alarm does not clear within thirty (30) minutes.

The system monitoring of the alarm wiring operates by reading the voltage on each of the alarm channels and responding as follows:

0.0 through 3.0 VDC	Alarm
3.1 through 6.0 VDC	Wiring warning. The MX16 blinks the "Service Needed" LED but does not initiate shutdown. This condition may indicate a serious decay on the wiring's insulation or water ingress into the end device.
6.1 through 8.0 VDC	Normal, no alarm
8.1 VDC and above	Wiring Failure (Open circuit)

The scanning of all channels is done by sending very short pulses to each alarm sensor; the microprocessor monitors and compares the voltage value with the voltage ranges shown above to determine the condition of each given alarm channel. Given the above, pulses are too fast for a regular voltmeter to read; a test mode is available where all sixteen (16) input channels so that voltages can be read with a regular voltmeter.

If the voltage of each channel is to be metered for troubleshooting purposes, then proceed as follows:

- Have the MX16 box un-latched.
- Have a voltmeter ready in the range of 12 VDC. To facilitate reading, connect the common to any convenient place on the enclosure.
- Press "Test" (next to the "RESET" switch) for about three (3) seconds.
- The field loop voltage will be present for sixty (60) seconds on all sixteen (16) channels.
- A normal reading (no alarm) will be between 7.0 and 7.6 VDC.
- An alarm condition will read below 3.0 VDC.
- If one of the channels has the EOZ (End Of line Zener) connected backwards, then the reading will be about 0.5 VDC and the alarm will not clear until the EOZ is connected correctly.

Alarm Sensor Test

- Also while in test mode, the operator can cause the closure of the contacts on any alarm switch and the MX16 will respond by flashing the corresponding alarm LED.
- For ending the "Test" routine the operator can press "RESET" and for confirming the MX16 is now on the Alarm and Shutdown mode, observe the "System OK" green LED which will be blinking once a second. Otherwise, the "Test" routine will terminate sixty (60) seconds after it begins.

Time Delays

Channels 13-16 can have ten (10) second alarm delays if desired. This is intended for connection to alarms such as level indications on tanks or separators where sloshing of fluids could result in false alarms. The user can select this mode on each channel by moving to the left the DIP switch associated with the channel where a ten (10) second alarm delay is desired. DIP switch options are indicated on the green label.

Other Options

In addition to alarm delays, the DIP switch also allows the user to specify whether the alarm outputs (Out 1 to Out 6) are normally open (NO) or normally closed (NC). For use with other Axiom equipment, the outputs should be set to normally open. Some SCADA systems may require that the outputs are set to normally closed for proper communication.

The remaining option determines the behavior of the MX16 when the battery is removed. When set to "Remove Batt ShutDn", the solenoid valve will close when the battery module is removed. When set to "No ShutDn", the solenoid will not close when the battery is removed. This is useful when the user wishes to replace the battery module without disrupting production.

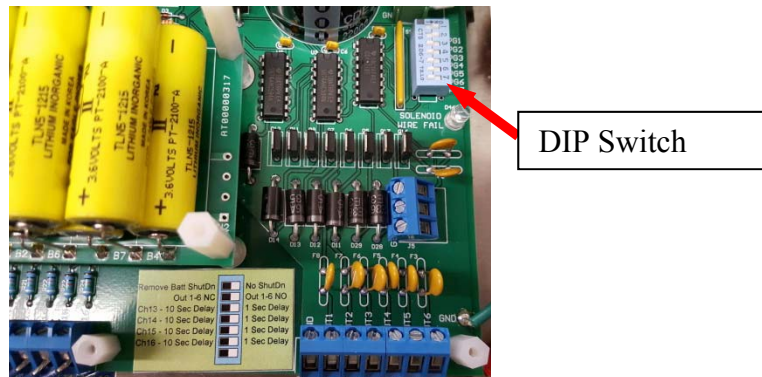

Fig. 4 User Options

PNEUMATICS

Control of the pneumatic actuator is done by the solenoid valve, mounted on the right side of the box.

The solenoid valve is a three way magnetically latched device that is pulsed to open and pulsed to close the path of pneumatic pressure to the actuator. It is a time tested device that has shown unsurpassed reliability, however, the reliability of this device depends on a clean pneumatic supply.

It is recommended that a filter is installed upstream the solenoid valve to stop particulate matter from entering the valve which can cause leakage and/or failure to latch, when commanded to reassume production.

The typical connection is as follows:

Port 1 (normally closed)	Supply Pneumatic Pressure (100 PSI Typ.)
Port 2 (common)	Actuator
Port 3 (normally open)	Exhaust

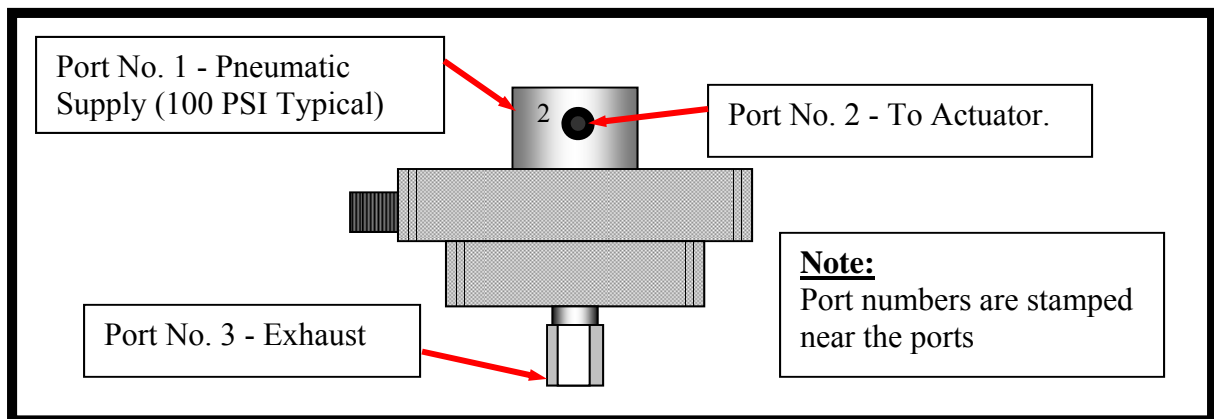

Fig. 5 Solenoid pneumatic typical connection

MX16 - ENVIRONMENTAL SPECIFICATIONS

- Temperature range : -40C to +85C
- Humidity range : 0 To 95% max., non-condensing
- Altitude : 4,000 m. max.
- Class I Division 2, Groups C & D, T4
- Class I Zone 2, IIB, T4

Intrinsically safe field wiring terminals J3 L1-L8 & J6 L9-L16 are suitable for Class I, Division 1, Groups C & D. Please reference AT-MX16-I for a wiring diagram.

MX16 - PRESSURE RATINGS

- Solenoid Valve Pressure : 100 psi max. (standard)
- 150 psi max. (optional)

MX16 - ELECTRICAL RATINGS

- Electrical Source : Dual voltage lithium battery module 3.6 & 14.4 VDC
- Current consumption : 20 mA max. on 3.6VDC Circuits
- 0.5 mA (3 A max. pulse) on 14.4VDC Circuits

MX16 – CERTIFICATION SPECIFICATIONS

Evaluated against the following standards:

- UL 913 (IS field wiring terminals only)
 - a) UL 60079-0
 - b) UL 60079-11
- UL 121201
- CSA 157 (IS field wiring terminals only)
- CSA 213

IS Terminals:

- $U_o = 15.6Vdc$
- $I_o = 0.291A$
- $P_o = 1.0W$
- $C_a = 3.03\mu F$
- $L_a = 1.6mH$

Non-incendive terminals J5:

- $U_i = 30Vdc$
- $I_i = 0.5A$
- $P_i = 15W$
- $C_i = \text{negligible}$
- $L_i = \text{negligible}$

Non incendive terminals J7:

- $U_i = 30Vdc$
- $I_i = 0.5A$
- $P_i = 15W$
- $C_i = \text{negligible}$
- $L_i = \text{negligible}$

 **WARNING!**

TO REDUCE THE RISK OF IGNITION OF HAZARDOUS ATMOSPHERES:
Do not open this enclosure unless the area is known free of ignitable
mixture of gases. Keep tightly closed when in operation.

Appendix "A" - MX16 Installation Notes

- 1 This apparatus is suitable for use in a Class 1, Division 2, Groups C & D or unclassified locations.
- 2 Entity parameters for field wiring to permit selection of apparatus for IS interconnection:
Uo = 15.6 Volts DC
Io = 0.291A
Po = 1.0W
Ca = 3.03 uF
La = 1.6mH
- 3 Use the following formulas to calculate the allowed capacitance (Ca') and inductance values (La') for field wiring used in the non-incendive field wiring circuit (Belden 8451 use for Example*):
Note: symbol "<" means less than (< 7)
Ca' = C pF/ft X length of wiring loop (ft) < Ca
Example*: Ca' = 33.45 pF/ft X 800 ft = 0.0268 uF < 12.6 uF
La' = L uH/ft X length of wiring loop (ft) < La
Example*: La' = 0.17uH/ft X 800 ft = 136.0 uH < 100.0 mH
- 4 The associated non-incendive field wiring apparatus shall not be connected in parallel unless this is permitted by the the associated non-incendive field wiring apparatus approval.
- 5 This apparatus is approved for connection to simple apparatus, two wire applications such as "dry" contacts, transistor open collector that would "pull signal to ground", etc.
Polarity requirements: J3 and J6-Input SIG are positive voltage (11 VDC); IS COMMON terminal block are return or ground connection.
- 6 Intrinsically Safe (IS) type loop monitored alarm inputs must be isolated from any non-IS wiring.
- 7 The solid stste outputs for shutdown and service alerts are rated non-incendive.

See Following Sections for Detailed Wiring Instructions and Illustrations

- 1- The MX16 operates with normally open contacts, a contact closure indicates that an alarm is present.
- 2- For supervising field wiring, each input channel is provided with a 7.5V "End Of line Zener" (EOZ) at the MX16's input terminals. At the time of installation, the EOZ is to be removed from the MX16 and re-installed at the end of the loop, connected in parallel with the alarm switch. If more than one alarm switch is daisy-chained, then the EOZ is to be installed at the very last switch. The EOZ at the end of the alarm wiring allows the MX16 to confirm the wiring's integrity.
- 3- The EOZ must be connected in the correct polarity, Blue wire to "Signal" and White wire to "Common". Connecting the EOZ on a reverse polarity will cause the corresponding channel to stay on alarm.
- 4- The alarm switch may be located up to 3,000FT from the MX16
- 5- Each input sends a pulse of about 11VDC to the alarm switch. If the EOZ is connected (as it should), then the voltage is cut down to 7.3VDC (+/- 0.3VDC) and the MX16 accepts this voltage as a normal condition. If the EOZ would be missing or the wiring to the alarm switch disconnected, then the voltage may rise above 8VDC which is considered a "Wiring Failure" and cause shutdown.
- 6- Multiple MX16s, MI6s, XP7s and XH5s may share a single alarm switch such as a tank level, ESD station or any "dry contact" alarm switch.
- 7- The alarm output of an MX16 can be used as input for another MX16, or an XH5, MI6 or XP7. Make sure the EOZ is properly connected for wiring supervision.
- 8- For reading field wiring voltage, push and hold toggle switch on "Test" for two or three seconds for the system to go into a "Test" cycle as described on the User's Manual.

Axiom Technologies

MX16 Wiring Diagram
Monitored Inputs for
Safety Shutdown System

Reference:	Sheet:	Rev:	Date:
AT-MX16-I	1 of 2	3	1/20/2018

MX16 Enclosure

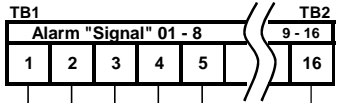

NOTES:

- All unused channels must have their respective End Of Line Zener connected as sent from factory for it to operate.
- Missing any EOZ will cause the system to alarm on "Wiring Failure" and prevent well from opening.
- A resistor of 15KOhm, no larger than 20 Kohm can be used as an emergency substitute of the EOZ.

Output Function	
3	- Shutdown
4	- Service Needed
5	- Alarm on Ch. 1-4
6	- Alarm on Ch. 5-8
7	- Alarm on Ch. 9-12
8	- Alarm on Ch. 13-16

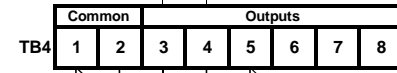

EOZ (Required for supervised loops - XP7, MI6, MX16, XH5, etc.)

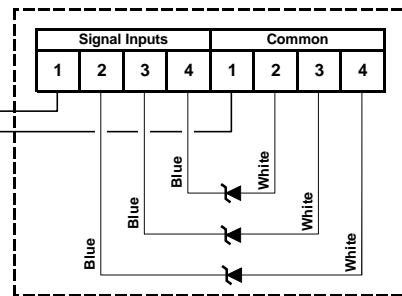

XP7 (Example Only)

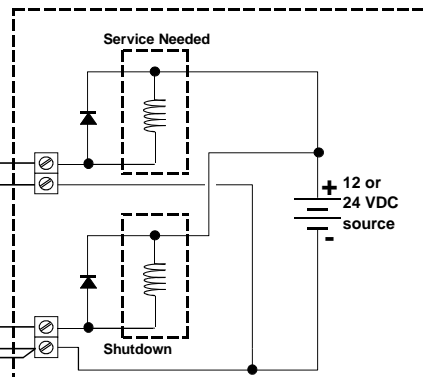

Control panel, external to the MX16 (Example Only)

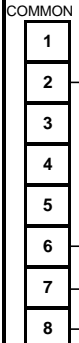

Blue Wire goes to "Signal"
White Wire "Common"

End-Of-line Zener (EOZ) on each input
Typical of 16 supplied with MX16
EOZ must be removed and installed with remote alarm switch as shown on channels 1 through 5 of this sheet
MUST BE CONNECTED FOR WIRING FAILURE ALARM TO GO AWAY!

Field Wiring

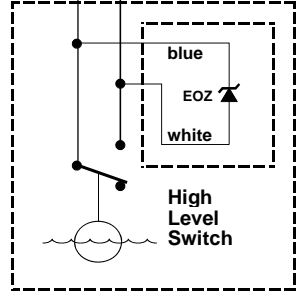

(High Tank Level)

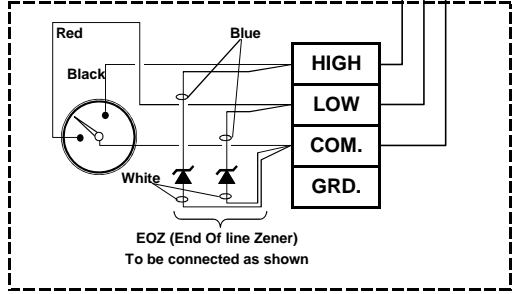

(Hi-Lo Pressure "Square" Switchgagge)

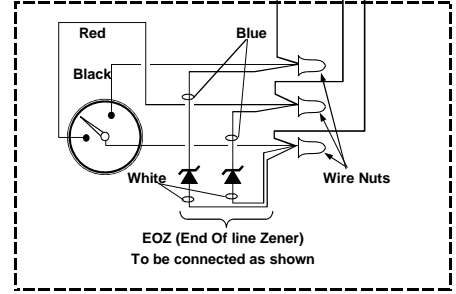

(Hi-Lo Pressure "Round" Switchgagge)

Polarity IS Important!

Axiom Technologies

MX16 Wiring Diagram
Monitored Inputs for Safety Shutdown System

Reference:	Sheet:	Rev:	Date:
AT-MX16-I	2 of 2	3	1/20/2018